

Customer Dwg:

MATERIAL: Copper
 PLATING: Electro-Tin
 STUD SIZE: "D" ±.005

VERSAKRIMP

BRAZE SEAM

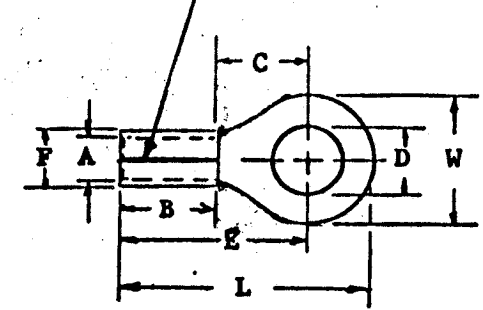

- 10 - .198
- 14 - .265
- 56 - .328
- 38 - .390
- 76 - .453
- 12 - .515
- 58 - .656
- 34 - .781
- 209 = .209
- 413 = .413

Customer Dimensions

Part No.	Wire Size	"W"	"C" Min	"E" Max	"B" Min	"L" Max	"A" Min	Stock Thkns. (A)	"F" Max	AVAILABLE STUD SIZE
F-366-	#4	.652 .678	.520	1.028	.425	1.385	.280	REF. .075	.470	209, 413 10, 14, 56, 38, 76, 12,
F-367-	#4	.465 .485	.520	1.028	.425	1.288	.280	REF. .075	.470	10, 14, 56
F-369-	#4	.875 .895	.989	1.497	.425	1.970	.280	REF. .075	.470	14, 56, 38, 76, 12, 58
F-370-	#4	1.250 1.270	.989	1.497	.425	2.158	.280	REF. .075	.470	14, 56, 38, 76, 12, 58, 34

For parts to be on tape add "T" at end of part number.



TITLE: "F" RING TONGUE TERMINAL

DIMENSIONAL TOLERANCE UNLESS OTHERWISE SPECIFIED

FRAC.	DEC.	ANG.
±	±	±

REVISION	SCALE: NONE	DATE
	DRWN. BY: LEM	3/2/70
	CHKD. BY:	
	APPRD. BY:	
A	ETC 50245 11/2 RGM	DRAWING NO.: