

THIS DRAWING IS UNPUBLISHED. RELEASED FOR PUBLICATION  
 © COPYRIGHT - By - ALL RIGHTS RESERVED.

LOC	DIST	REVISIONS					
DF	D0	P	LTR	DESCRIPTION	DATE	DWN	APVD
		J1		REVISED PER ECO-11-005030	11MAR11	RK	HMR

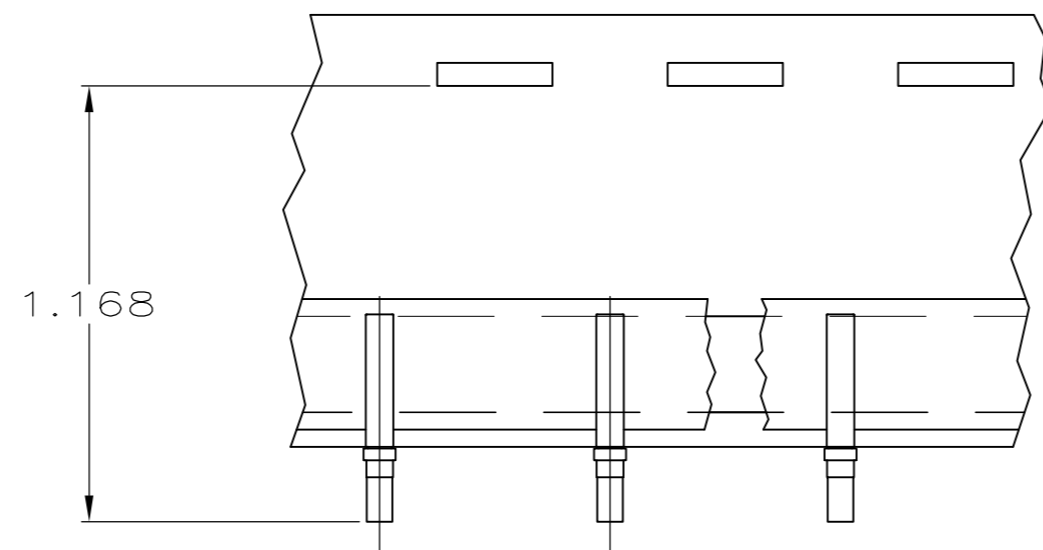
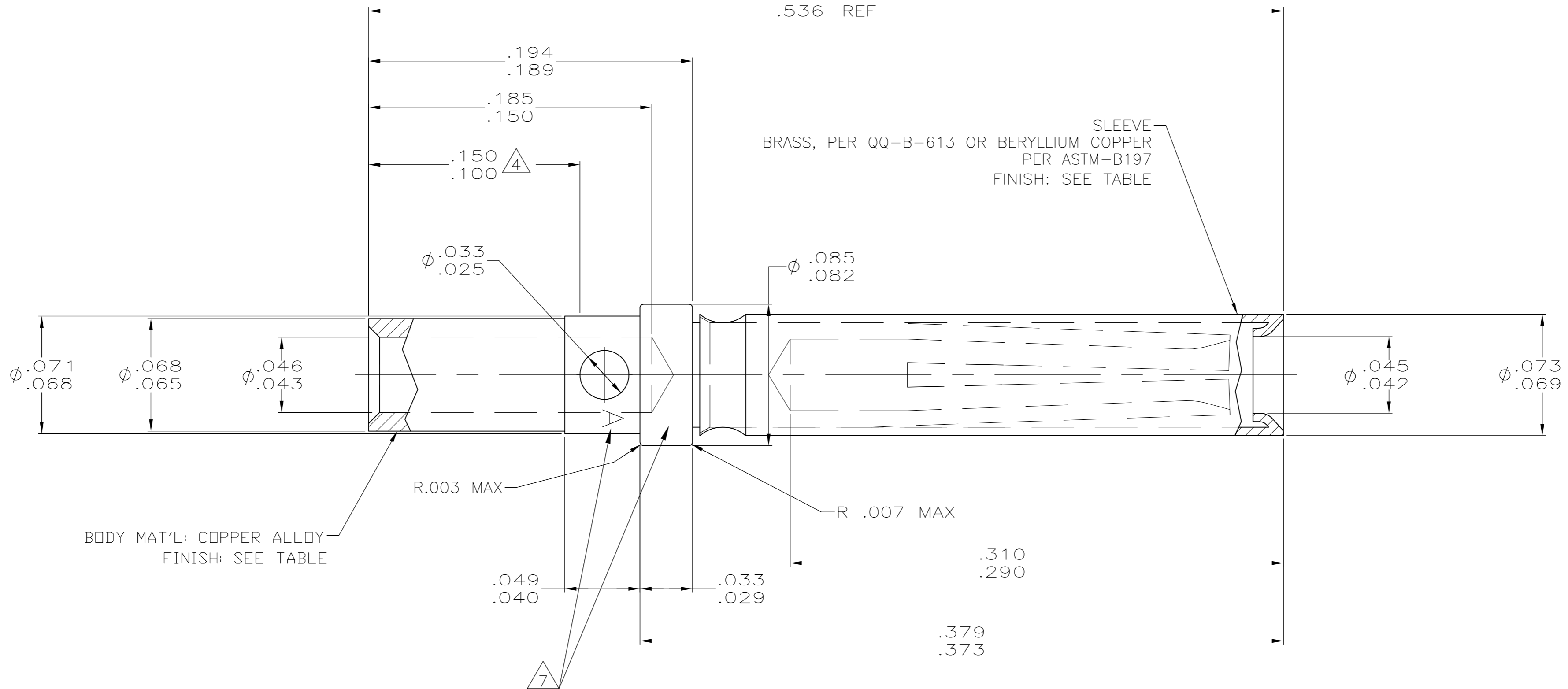

- CONTACTS MUST MEET ALL REQUIREMENTS OF GSFC-S-311-P-4/08 AND AS39029.
- ALL DIAMETERS ARE CONCENTRIC WITH EACH OTHER WITHIN  $.004$  T.I.R.
- ALL SURFACES HAVE  $63\sqrt{\text{ }}$  OR BETTER FINISH. POINT OF PLATING THICKNESS MEASUREMENT.
- SLEEVE MAY BE CRIMPED OR DIMPLED TO BODY.
- ~~MINIMUM SEPERATION FORCE OF 7 OZ USING A .039 PIN AND 4 OZ MAX ENGAGEMENT FORCE USING A .041 PIN.~~
- OPTIONAL LOCATION FOR STAMPED LETTER "A"
- PLATING: GOLD PER ASTM-B-488 (TYPEII) OVER COPPER PER MIL-C-14550, CLASS 4.
- PLATING: GOLD PER ASTM-B-488 (TYPEII) OVER NICKEL PER QQ-N-290.

	9	AS SHOWN	206793-4
OBSOLETE	8	SAME AS -1 EXCEPT 6	206793-3
	8	SAME AS -1 EXCEPT TAPE MOUNTED 5,000 CONTACTS PER REEL	206793-2
	8	AS SHOWN	206793-1
	FINISH	DESCRIPTION	PART NO

DIMENSIONS:		TOLERANCES UNLESS OTHERWISE SPECIFIED:		DWN		CHK		APVD		NAME		SIZE		CAGE CODE		DRAWING NO		RESTRICTED TO	
INCHES		0 PLC	$\pm$ -	C.C.THOMAS		D.MILLER		D.MILLER		SOCKET CONTACT ASSY, SIZE 20, AMPLIMITE		A2		00779		C-206793		-	
MATERIAL		1 PLC	$\pm$ -	11-20-02		11-20-02		11-20-02		-		SCALE		SHEET		REV		-	
SEE CALLOUT		2 PLC	$\pm$ -	-		-		-		CUSTOMER DRAWING		20:1		1 of 1		J1		-	
		3 PLC	$\pm$ -	-		-		-											
		4 PLC	$\pm$ -	-		-		-											
		ANGLES	$\pm$ -	-		-		-											
		FINISH	-	-		-		-											