

THIS DRAWING IS UNPUBLISHED. RELEASED FOR PUBLICATION, 19 .
 © COPYRIGHT 19 BY AMP INCORPORATED. ALL INTERNATIONAL RIGHTS RESERVED.

LOC	DIST	P	F	REVISIONS				
				ZONE	LTR	DESCRIPTION	DATE	APPD
AJ	16	✓	✓		A	REV & REDRAWN ADD 1-0,1-1,1-3,1-4,1-6 & 1-7	6-11-90	MS
		✓	✓		B	REV PER AJ-4992	2-20-91	JL
					C	REVISED PER 0503-0666-97	11-20-97	JG

- 1 BRASS PER QQ-B-626
- 2 TIN PLATE PER ASTM-B-545
- 3 SILVER PLATE PER QQ-S-365
- 4 0.76µm [.000030] MIN GOLD PLATE PER MIL-G-45204 OVER
0.76µm [.000030] MIN NICKEL PLATE PER QQ-N-290

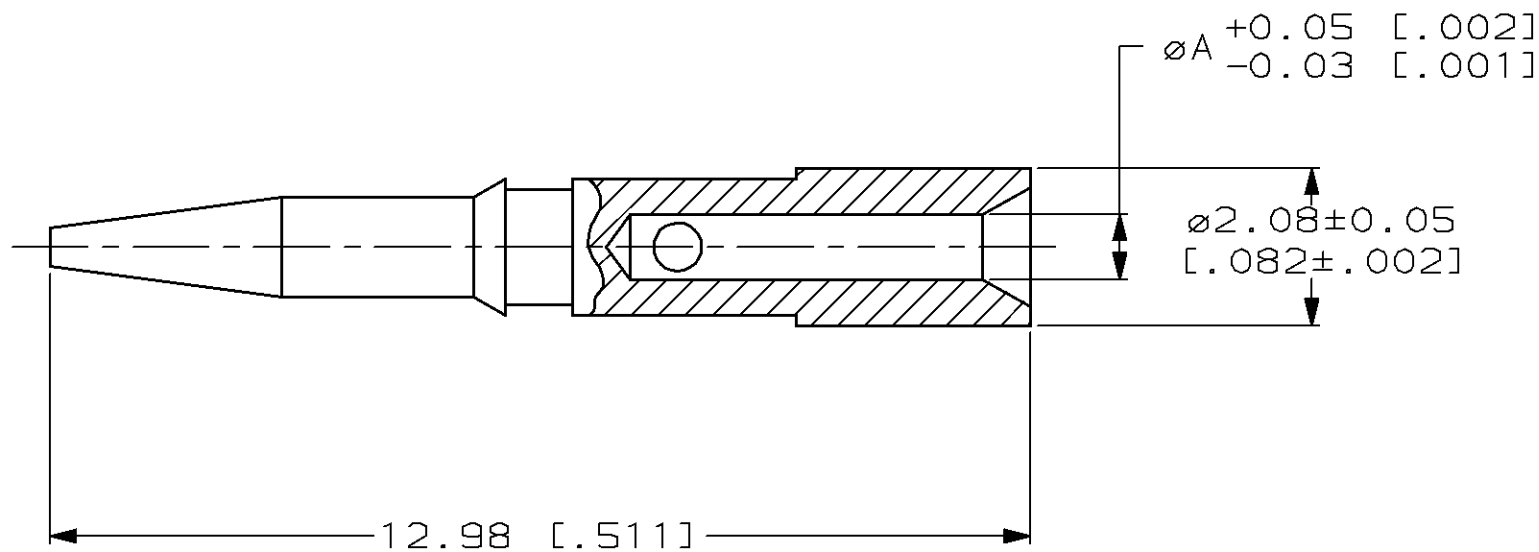

1.12 [.044]	3	1-222246-7
1.12 [.044]	4	1-222246-6
0.46 [.018]	3	1-222246-4
0.46 [.018]	4	1-222246-3
0.61 [.024]	3	1-222246-1
0.61 [.024]	4	1-222246-0
0.79 [.031]	2	222246-8
0.99 [.039]	2	222246-7
0.79 [.031]	3	222246-6
0.99 [.039]	3	222246-5
0.79 [.031]	4	222246-4
0.99 [.039]	4	222246-2

A DIA		FINISH	PART NO
DO NOT SCALE PRINT. UNLESS SPECIFIED DIMENSIONS IN mm [INCHES] TOLERANCES ON: 2 PLC DEC ± 0.13 [.005] 3 PLC DEC ± - ANGLES ± -		DR M. SNEED 6-4-90	AMP AMP Incorporated Harrisburg, PA 17105-3608
MATERIAL 1		CHK D. LAMAN 7-10-90	
FINISH 2 THRU 4		APPD M. PHILLIPS 7-12-90	NAME CONTACT, COMMERCIAL BNC
		APPD D. LAMAN 7-10-90	SIZE B CAGE CODE 00779 DRAWING NO 222246
		PRODUCT SPEC -	SCALE 10:1 SHEET 1 OF 1
		APPLICATION SPEC -	
		WEIGHT -	