

PART NUMBER	SML-LX2832GC-TR	REV.	F
DATE	E.C.N. NUMBER AND REVISION COMMENTS		REV.
03.14.03	E.C.N. #10967.		A
02.08.05	E.C.N. #11148.		B
03.16.07	E.C.N. #11402.		C
10.17.07	E.C.N. #11450.		D
05.04.10	E.C.N. #11627.		E
03.29.12	E.C.N. #11812 & #10BRDR. & REDRAWN.		F

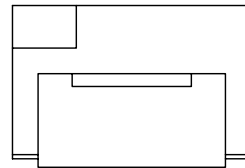

(D) RECOMMENDED SOLDER PAD LAYOUT

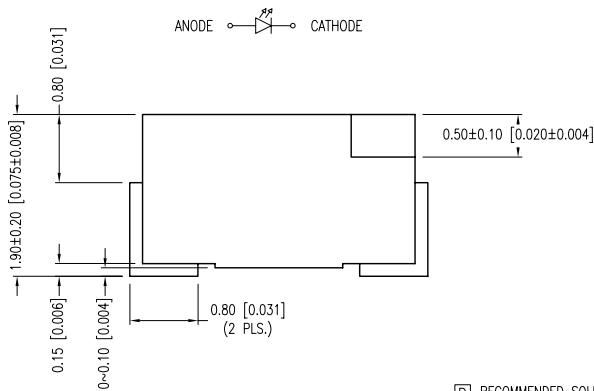
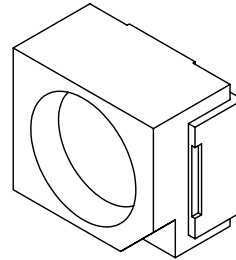
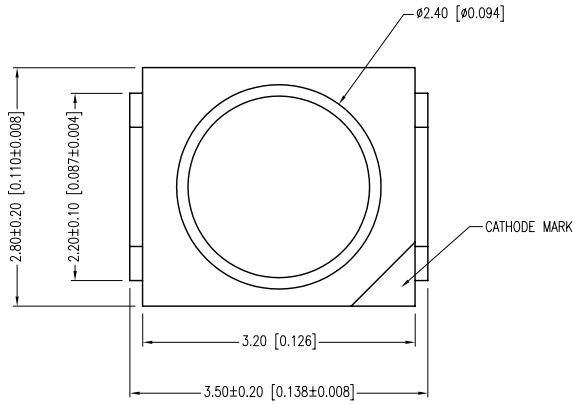
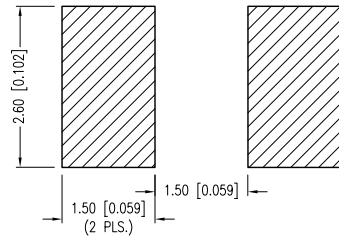

ELECTRO-OPTICAL CHARACTERISTICS $T_a=25^\circ\text{C}$ $I_f=20\text{mA}$					
PARAMETER	MIN	TYP	MAX	UNITS	TEST COND
PEAK WAVELENGTH		565		nm	
FORWARD VOLTAGE		2.1	2.8	Vf	
REVERSE VOLTAGE	5.0			Vr	$I_r=100\mu\text{A}$
AXIAL INTENSITY		25		md	$I_f=20\text{mA}$
VIEWING ANGLE		120		$2x$ theta	
EMITTED COLOR:	GREEN				
LENS FINISH:	WATER CLEAR				

LIMITS OF SAFE OPERATION AT 25°C		
PARAMETER	MAX	UNITS
PEAK FORWARD CURRENT*	160	mA
STEADY CURRENT	25	mA
POWER DISSIPATION	100	mW
DERATE FROM 25°C	-1.2	$\text{mW}/^\circ\text{C}$
OPERATING TEMP.	-40 TO +85	$^\circ\text{C}$
STORAGE TEMP.	-40 TO +85	$^\circ\text{C}$
SOLDERING TEMP.	+260	$^\circ\text{C}$
2.0mm FROM BODY	3	SEC.

* $t < 10\mu\text{s}$

F E A CAUTION: MOISTURE SENSITIVE DEVICE PER JEDEC LEVEL 3 STANDARDS

*UNLESS OTHERWISE SPECIFIED TOLERANCES PER DECIMAL PRECISION ARE: X=±1 (±0.039), X.X=±0.5 (±0.020), X.XX=±0.25 (±0.010), X.XXX=±0.127 (±0.005). LEAD SIZE=±0.05 (±0.002), LEAD LENGTH=±0.75 (±0.030). MIN= $^{+0.000}_{-0.000}$ DECIMAL PRECISION MAX.= $^{+0.000}_{-0.000}$ DECIMAL PRECISION



290 E. HELEN ROAD
PALATINE, IL 60067-6976
PHONE: +1.847.359.2790
FAX: +1.847.359.6538
WEB: WWW.LUMEX.COM
MEMBER OF ITW PHOTONICS GROUP

2.8mm X 3.2mm SML W/REFLECTOR, 565nm GREEN LED, WATER CLEAR LENS, TAPE & REEL.

THE SPECIFICATIONS MAY CHANGE AT ANY TIME WITHOUT NOTICE DUE TO NEW MATERIALS OR PRODUCT IMPROVEMENT.

CONFIDENTIAL INFORMATION
THE INFORMATION CONTAINED IN THIS DOCUMENT IS THE PROPERTY OF LUMEX INC. EXCEPT AS SPECIFICALLY AUTHORIZED IN WRITING BY LUMEX INC., THE HOLDER OF THIS DOCUMENT SHALL KEEP ALL INFORMATION CONTAINED HEREIN CONFIDENTIAL AND SHALL PROTECT SAME IN WHOLE OR IN PART FROM DISCLOSURE AND DISSEMINATION TO ALL THIRD PARTIES.

DATE:	03.29.12	DRAWN BY:	AB
PAGE:	1 OF 2	CHKD BY:	KF
SCALE:	NTS	APRVD BY:	KF
UNIT:	mm [INCH]		